

Operating Instructions
Felling Wedge TR 24



Content

1	Technical Data	1
2	Area of Application – Designated Use	1
3	Safety Instructions	2
4	Warranty.....	2
5	Application.....	3
6	Maintenance/Testing	4
7	Tips.....	4
8	Exploded View	5
9	EC Declaration of Conformity	6

1 Technical Data

Designation	Mechanical Felling Wedge TR24
max compressive force (t)	8
mass (kg)	2.8
length (mm)	350
width (mm)	80
height (mm)	73
stroke/revolution (mm)	5
max torque (Nm)	80 Nm

2 Area of Application – Designated Use

The mechanical felling wedge **TR24** is used in logging as a replacement for strenuous wedge work or as an alternative to the hydraulic felling wedge.

Advantages over classic wedge work:

- vibration-free wedging
- “toppling” the tree is ergonomically cheap and easy on the joints

Advantages over hydraulic felling wedges:

- light weight
- easy maintenance
- good ergonomics with telescopic ratchet

This device does not replace wire ropes and winches. Only use it if you believe that the tree could be felled with classic wedges. Do not try to fell trees with the mechanical felling wedge that have a pronounced side or back lean in order to avoid overloading the device. Make sure you are familiar with this device before you use it.

If the mechanical felling wedge is

- not used as intended
- overloaded
- not or poorly maintained

the manufacturer will assume no liability for damages incurred.

3 Safety Instructions



Danger:

Failure to follow instructions may result in severe injuries or even death!

- **Always** work with normal plastic or aluminum wedges for support. Make sure to keep feeding in the wedges when operating the mechanical felling wedge.
- The maximum torque for the mechanical felling wedge is **80 Nm**. Apply no more than **31 kg** manual force to the extended telescopic ratchet (approx. 580 mm lever length) to avoid overloading the spindle.
- This device does not replace wire ropes and winches. Only use it if you believe that the tree could be felled with classic wedges. Do not try to fell trees with the mechanical felling wedge that have a pronounced side or back lean in order to avoid overloading the device. Make sure you are familiar with this device before you use it.
- Do **not** forcibly drive the mechanical felling wedge TR24 into the felling cut. You might damage the hexagon head and nut.
- Do **not** push or hit the felling wedge. This could bend the threaded spindle.

4 Warranty

We provide a warranty on the function and flawlessness of the material for 12 months starting from the date of delivery for the mechanical felling wedge TR24. This does not cover the consequences of normal wear and tear, overloading, improper treatment, or the installation of foreign spare parts.

A warranty can only be provided if the device has been submitted to us in one piece without tampering for testing. Damage caused by material or manufacturing faults will be repaired or replaced free of charge.

5 Application

Felling:

Set the supplied flexible head ratchet to a right rotation. The wedge can be driven in until the threading on the outside is no longer visible and the telescopic ratchet touches the nut.

Wedge retrieval:

Set the supplied flexible head ratchet to a left rotation. Wind the wedge back until it touches the nut.

Felling a tree of normal strength:

- Apply a proper felling technique in accordance with the good, professional practice of forest work.
- Place classic wedges in the saw cut to keep it open.
- Use the saw **to widen** the cut at the top and bottom before applying the mechanical felling wedge **TR24**. Make sure it fits cleanly into the felling cut with all “barbed hooks”. Both spring steel plates must engage the wood evenly.
- Place the mechanical felling wedge **TR24** horizontally into the saw cut (if the wedge is inserted diagonally up or down, this can lead to increased wear and fatigue).
- Carefully drive the wedge into the saw cut using the ratchet until the tree starts to fall.
- Keep feeding the classic wedges for support while driving the felling wedge **TR24** further into the cut.

6 Maintenance/Testing



Please observe the maintenance instructions:

- The mechanical felling wedge **TR24** must undergo a visual inspection for damages before each use.
- Make sure that the threaded spindle/nut is sufficiently lubricated **before each use**. Lubricate the threaded spindle/nut at the grease nipple provided for this purpose and rotate the spindle once both ways. The nut must be checked regularly for wear.
- Make sure that the surfaces between wedge and spring steel plates are lubricated **before each use**. This way, the wear is lessened and the applied force necessity of the operator significantly reduced.
- Keep the mechanical felling wedge clean at all times to increase its service life.
- Only original spare parts may be used. Contact your local dealer for more information.
- The following lubricant was used for the initial lubrication:
Fuchs Gleitmo 805 – white high-performance lubricant for long-term lubrication

7 Tips

- Regularly switching the two steel plates is recommended to account for the loads varying between top and bottom due to askew placement. Thus, creating less bend in the spring steel plates.
- If the spring steel plates are bent, they can simply be set by hand.

Operating Instructions

Mechanical Felling Wedge TR24

8 Exploded View

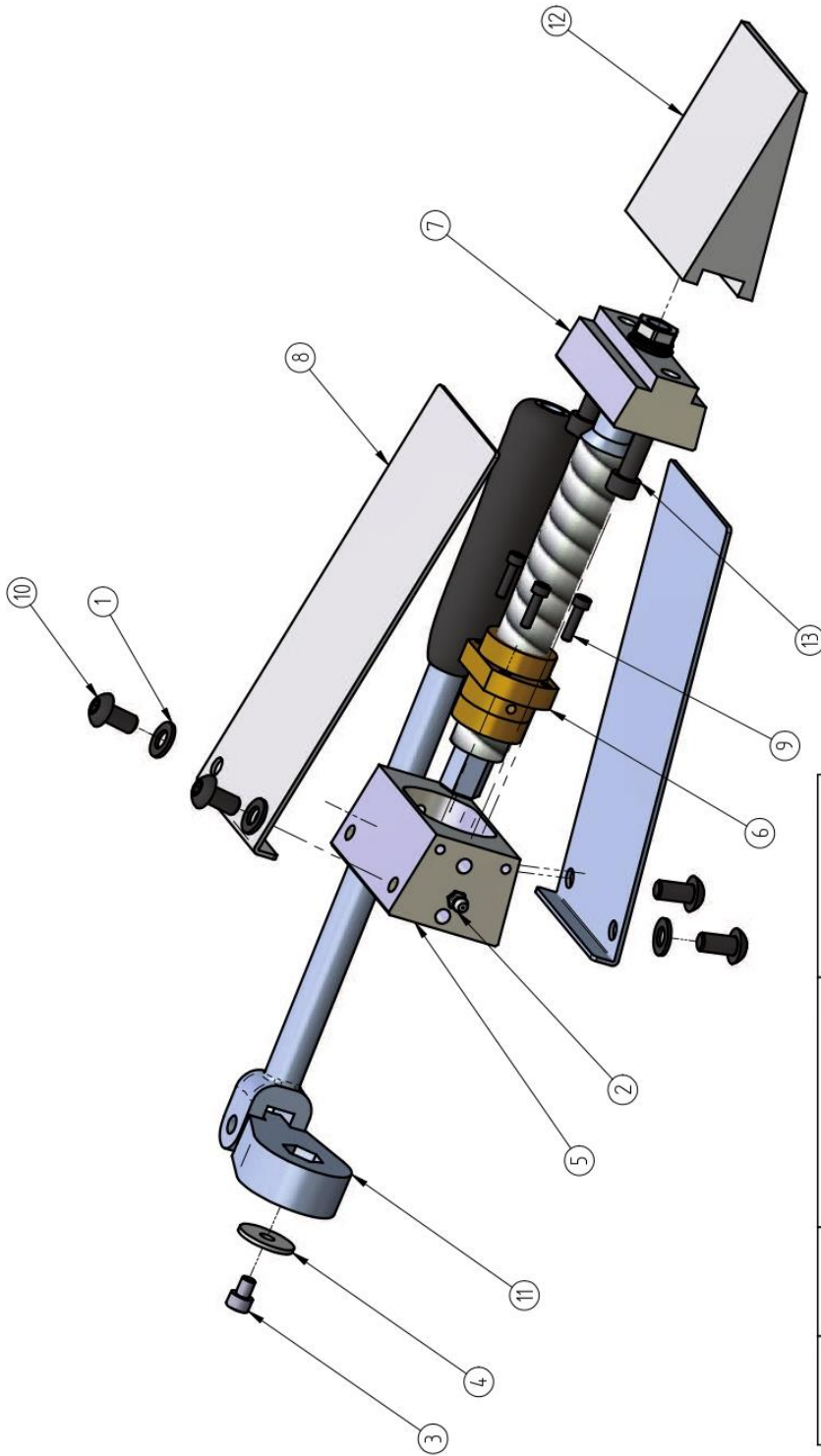

Pos.	Stk.	Projekt	Artikelnummer
1	4	Washer Ø8,4 DIN 125	001-1010.par
2	1	Grease nipple M6x0,75	001-1012.par
3	1	Cylindrical head screw M6x8 DIN 912 10.9	001-1014.par
4	1	Large-diameter washer Ø6 x 25	001-1026.par
5	1	Block	003-1002.par
6	1	Nut TR24 x 5	003-1004.par
7	1	Spindle with Thrust bearing and Block	003-1005.asm
8	2	Spring steel plate	003-1006.psm

Pos.	Stk.	Projekt	Artikelnummer
9	4	Cylindrical head screw M4x16 DIN 912	003-1008.par
10	4	Cylindrical head screw M8x16 ISO 7380	003-1009.par
11	1	Ratchet	003-1011.par
12	1	Wedge	003-1018.par
13	2	Cylindrical Head Screw M8x30 DIN912	003-1023.par

Operating Instructions
Mechanical Felling Wedge TR24

forstreich 
maschinenbau

9 EC Declaration of Conformity

Manufacturer: Forstreich-Maschinenbau
Prop. Stefan Reichenbach
Schwarzwaldstr.314
79117 Freiburg
Phone: +49(0)151/11030401

hereby declares that the following product:

Product description: mechanical felling wedge **TR24**
Year of manufacture: as of 05/2019

complies with all the relevant regulations of the **Machinery Directive (2006/42/EC)**.

The following harmonized standards apply:

EN ISO 12100 Safety of machinery – General principles for design
Risk assessment and risk reduction

Freiburg, May 16th, 2019



Date

Signature

forstreich maschinenbau

As of 05/19

Subject to technical changes